

# MAGNUS

**Bomba autoaspirante para piscina**  
*Self priming pump for swimming pools*  
**Pompe auto-aspirante pour piscine**

efficiency class

**IE3**

1.450 r.p.m



- ✓ **Polipropileno + Fibra de Vidrio**  
*Polypropylene + Fiberglass*  
Polypropylène + Fibre de Verre
- ✓ **Eje en acero inoxidable AISI-316**  
*AISI-316 stainless steel shaft*  
Manche en acier inoxydable AISI-316
- ✓ **Rodete en Noryl**  
*Impeller in Noryl*  
Turbine à Noryl
- ✓ **Sello mecánico en acero inoxidable AISI-316**  
*Mechanical seal in stainless steel AISI-316*  
Garniture mécanique en acier inoxydable AISI-316
- ✓ **Funcionamiento a 1450 rpm hasta 10 CV**  
*Operation at 1450 rpm up to 10 HP*  
Fonctionnement à 1450 tr/min jusqu'à 10 CV



Turbina de bronce bajo demanda  
*Bronze impeller on demand*  
Turbine en bronze sur demande



- |   |   |   |
|---|---|---|
| ➤ Conexión brida 110mm (4 pulgadas)                 | Flange connection 110mm (4 inches)                    | Raccordement à bride 110 mm (4 pouces)                    |
| ➤ Cesto prefiltro de gran tamaño                    | Large pre-filter basket                               | Grand panier préfiltre                                    |
| ➤ <b>Pintura por cataforesis</b>                    | <b>Cataphoresis painting</b>                          | <b>Peinture de cataphorèse</b>                            |
| ➤ Base soporte de Noryl                             | Noryl support base                                    | Base de support en Noryl                                  |
| ➤ Tornillería en acero inoxidable AISI-316          | Stainless steel screws AISI-316                       | Vis en acier inoxydable AISI-316                          |
| ➤ Motor asíncrono IE3 a 1450 rpm (1750 rpm @ 60 Hz) | IE3 asynchronous motor at 1450 rpm (1750 rpm @ 60 Hz) | Moteur asynchrone IE3 à 1450 tr/min (1750 tr/min @ 60 Hz) |
| ➤ Rodamientos lubricados de por vida                | Lubricated bearings for life                          | Roulements lubrifiés à vie                                |
| ➤ Grado IP-55, Aislamiento clase F                  | IP-55 Grade, Class F Insulation                       | Isolation IP-55, classe F                                 |
| ➤ Máxima temperatura del agua: +40°C                | Maximum water temperature: +40°C                      | Température maximale de l'eau: +40°C                      |

Datos Técnicos / Technical data / Données techniques

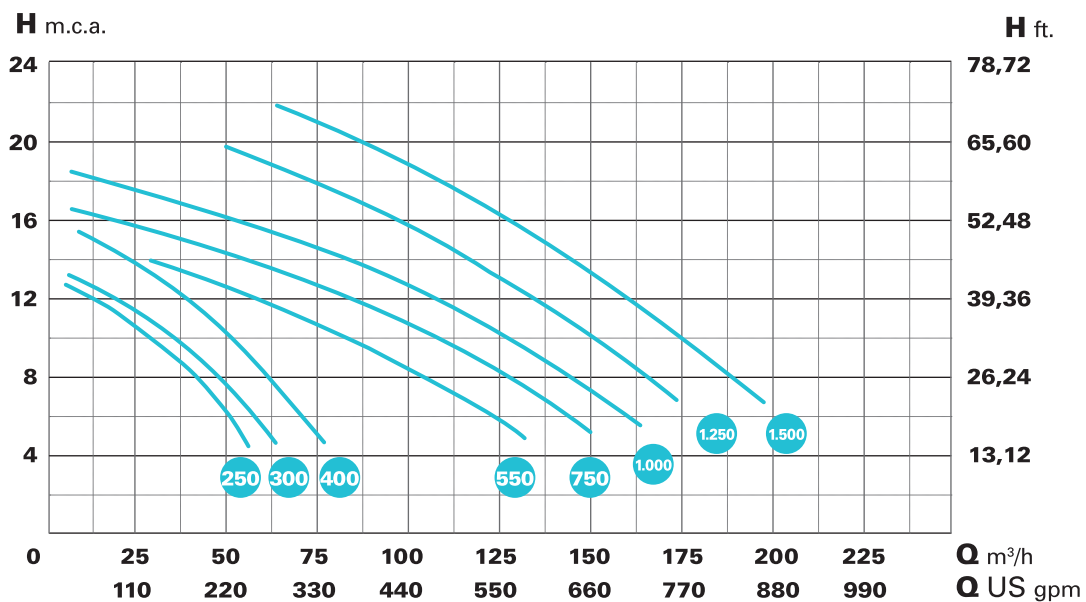

Tipo / Type	HP	KW	A		R.P.M.	Altura manométrica m.c.a. / Manometric height w.c.m.										Diámetro		Mínimo diámetro de aspiración / Minimum size of suction pipe
			III 230	III 400		6	8	10	12	14	16	18	20	22	ASP.	IMP.		
Caudal m³/h / Flow m³/h																		
MAGNUS-4 250	2,5	1,8	8,5	4,9	1,450	53	43	32	18	-	-	-	-	-	110	110	110	
MAGNUS-4 300	3	2,2	9,4	5,3	1,450	62	54	43	26	10	-	-	-	-	110	110	125	
MAGNUS-4 400	4	3	12,5	6,9	1,450	74	66	56	42	29	14	-	-	-	110	110	140	
MAGNUS-4 550	5,5	4	15,3	8,8	1,450	123	104	84	57	30	-	-	-	-	110	110	160	
MAGNUS-4 750	7,5	5,5	-	12	1,450	143	127	107	85	57	12	-	-	-	110	110	180	
MAGNUS-4 1000	10	7,5	-	15,8	1,450	160	145	126	107	80	48	14	-	-	110	110	180	
MAGNUS-2 1250	12,5	9,2	-	18,5	2,850	-	167	152	136	118	99	80	47	-	110	110	180	
MAGNUS-2 1500	15	11	-	20,9	2,850	-	188	177	162	146	130	112	92	66	110	110	200	

# MAGNUS

Datos embalaje  
Packaging data  
Données d'emballage

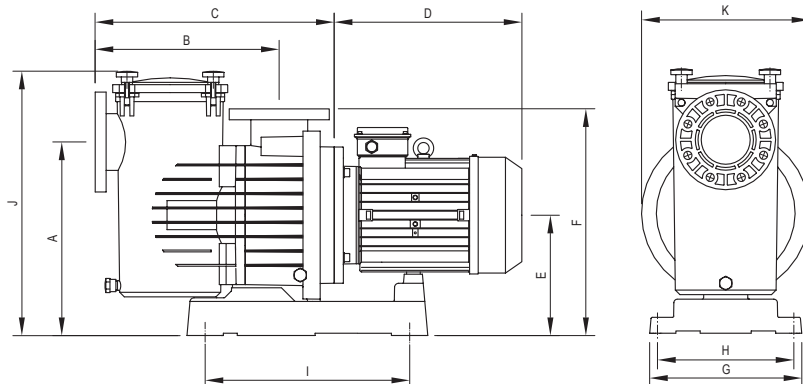
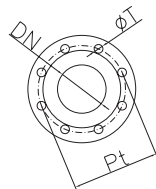
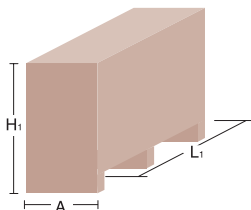

Tipo / Type	A	B	C	D	E	F	G	H	I	J	K	DN	øT	Pt	A1	H1	L1	Peso Kg.
<b>MAGNUS-4 250</b>	423	405	527	310	267	500	335	300	450	596	368	110	18	180	385	595	840	42
<b>MAGNUS-4 300</b>	423	405	527	310	267	500	335	300	450	596	368	110	18	180	385	595	840	42,5
<b>MAGNUS-4 400</b>	423	405	527	310	267	500	335	300	450	596	368	110	18	180	385	595	840	44,5
<b>MAGNUS-4 550</b>	423	405	527	335	267	500	335	300	450	596	368	110	18	180	385	715	1.170	53,4
<b>MAGNUS-4 750</b>	423	405	527	385	267	500	335	300	450	596	368	110	18	180	385	715	1.170	66
<b>MAGNUS-4 1000</b>	423	405	527	385	267	500	335	300	450	596	368	110	18	180	385	715	1.170	76
<b>MAGNUS-2 1250</b>	423	405	527	385	267	500	335	300	450	596	368	110	18	180	385	715	1.170	84,5
<b>MAGNUS-2 1500</b>	423	405	527	385	267	500	335	300	450	596	368	110	18	180	385	715	1.170	85,5

Denominación recambios  
Spare-part description  
Dénomination des pièces

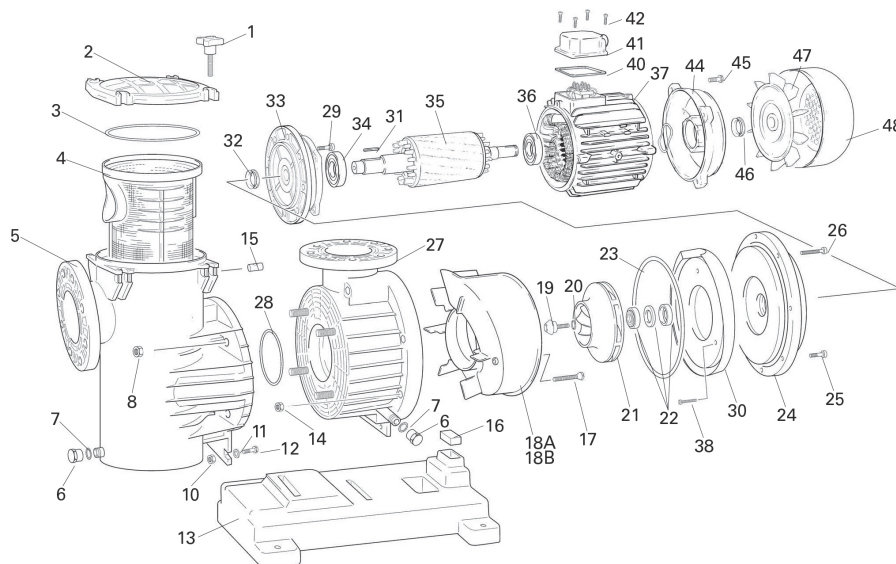

- 1 - POMOS
- 2 - TAPA PREFILTRO
- 3 - JUNTA TÓRICA TAPA PREFILTRO
- 4 - CESTO PREFILTRO
- 5 - CUERPO PREFILTRO
- 6 - TAPÓN DESAGUE
- 7 - JUNTA PLANA TAPÓN DESAGÜE
- 8 - TUERCA FIJACIÓN PREF-CUERPO
- 10 - TUERCA FIJACIÓN BASE
- 11 - ARANDELA FIJACIÓN BASE
- 12 - TORNILLO FIJACIÓN BASE
- 13 - BASE BOMBA
- 14 - TUERCA FIJACIÓN CUERPO-CUERPO
- 15 - CILINDRO PORTAPOMO
- 16 - TACO GOMA SOPORTE MAGNUS
- 17 - TORNILLO FIJACIÓN VOLUTA
- 18A - VOLUTA 1.450 RPM
- 18B - VOLUTA 2.850 RPM
- 19 - TAPÓN+TORNILLO RODETE
- 20 - JUNTA TÓRICA TAPÓN TURBINA
- 21 - TURBINA 1450 - 2.850 RPM
- 22 - SELLO MECÁNICO
- 23 - JUNTA TAPA CUERPO BOMBA
- 24 - TAPA CUERPO BOMBA



- 1 - HANDLES
- 2 - PRE-FILTER COVER
- 3 - PRE-FILTER COVER O-RING
- 4 - PRE-FILTER BASKET
- 5 - PRE-FILTER BODY
- 6 - DRAIN STOPPER
- 7 - DRAIN STOPPER O-RING
- 8 - PRE-FILTER-BODY NUT
- 10 - BASE SECURING NUT
- 11 - BASE SECURING WASHER
- 12 - BASE SECURING SCREW
- 13 - PUMP BASE
- 14 - BODY-BODY SECURING NUT
- 15 - CLOSURE PIN BOLT
- 16 - MAGNUS RUBBER SHIM
- 17 - VOLUTE SECURING SCREW
- 18A - 1,450 RPM VOLUTE
- 18B - 2,850 RPM VOLUTE
- 19 - IMPELLER PLUG + SCREW
- 20 - TURBINE PLUG O-RING
- 21 - 1,450 - 2,850 RPM TURBINE
- 22 - MECHANICAL SEAL
- 23 - PUMP BODY COVER JOINT
- 24 - PUMP BODY COVER



- 1 - POIGNÉES.
- 2 - COUVERCLE PRÉFILTRE
- 3 - JOINT TORIQUE COUVERCLE PRÉFILTRE
- 4 - PANIER PRÉFILTRE
- 5 - CORPS PRÉFILTRE
- 6 - BOUCHON VIDANGE
- 7 - JOINT PLAT BOUCHON VIDANGE
- 8 - ÉCROU FIXATION PRÉFILTRE-CORPS
- 10 - ÉCROU FIXATION BASE
- 11 - RONDELLE FIXATION BASE
- 12 - VIS FIXATION BASE
- 13 - BASE POMPE
- 14 - ÉCROU FIXATION CORPS-CORPS
- 15 - CYLINDRE PORTE-POIGNÉE
- 16 - TAQUET CAOUTCHOUC SUPPORT MAGNUS
- 17 - VIS FIXATION VOLUTE
- 18A - VOLUTE 1450 T/MIN
- 18B - VOLUTE 2850 T/MIN
- 19 - BOUCHON + VIS ROUE
- 20 - JOINT TORIQUE BOUCHON TURBINE
- 21 - TURBINE 1450 - 2850 T/MIN
- 22 - SCEAU MÉCANIQUE
- 23 - JOINT COUVERCLE CORPS POMPE

- 24 - COUVERCLE CORPS POMPE
- 25 - VIS COURTE FIXATION CORPS
- 26 - VIS LONGUE FIXATION CORPS
- 27 - CORPS POMPE
- 28 - JOINT TORIQUE PRÉFILTRE - CORPS
- 29 - VIS FIXATION MOTEUR
- 30 - ANTI VOLUTE
- 31 - GOUPILLE
- 32 - BUTÉE CAPOT ARRIÈRE MOTEUR
- 33 - VIS FIXATION ANTI VOLUTE
- 34 - ROULEMENT AVANT
- 35 - AXE ROTOR
- 36 - ROULEMENT ARRIÈRE
- 37 - STATOR AVEC CARCASSE
- 38 - VIS FIXATION ANTI VOLUTE
- 40 - JOINT CAPOT CONNEXIONS
- 41 - CAPOT CONNEXIONS
- 42 - VIS CONNEXIONS
- 44 - CAPOT ARRIÈRE MOTEUR
- 45 - VIS CAPOT ARRIÈRE
- 46 - BUTÉE CAPOT ARRIÈRE MOTEUR
- 47 - VENTILATEUR
- 48 - CAPOT VENTILATEUR